

DIAMOND Gear Company, LTD.

Installation, Maintenance, & Operation Manual

DECLUTCHABLE WORM GEAR



2021



DECLUTCHABLE WORM GEAR Installation, Maintenance, & Operation Manual

INSTRUCTIONS

This is an instructional manual which provides general installation, operation, and maintenance for Diamond Gear Declutchable Override worm gear operators.

Diamond Declutchable Worm Gear operators are designed to be used on ball, butterfly, plug, and damper applications; generally for 90 degree applications. Diamond Declutchable Worm Gear operators are designed to transmit the rated output torque by transmitting input force through the input shaft by the handwheel or directly with the use of an actuator.

INSTALLATION

Verify that mounting patterns and output bore have been machined correctly. Check for burrs on valve stem and inside gear to ensure easy installation.

1. Make sure that both the valve and gear are in the same position (Open or Closed)
2. Removing the gear indicator will make it easier to install the gear and line up input bore with the valve stem.
3. Line up stem shaft on the valve with the output bore of the gear. Reassure that both gear operator and valve are in the same open or closed position. Carefully lower gear operator over the valve stem onto the valve mounting pad.



Make certain your hands and fingers are clear between the gear operator and mounting pad.

4. Align the mounting holes on the bottom of the gear operator with those on the mounting pad or bracket on the valve.



If the holes are not aligned you might need to rotate the handwheel clockwise or counterclockwise until you reach the proper alignment.

5. DGC recommends grade 5 or better bolting when securing the gear operator to the valve mounting pad and/or bracket. If the operator is provided with tapped holes in the base, fasten the operator to the valve by passing bolts through the mounting flange of the valve into the base of the operator.



DECLUTCHABLE WORM GEAR Installation, Maintenance, & Operation Manual

SETTING ADJUSTMENT SCREWS

1. Before using the actuator make sure the adjustment screws on the gear are out. Using the handwheel or actuator move the valve to the fully closed position and set the actuator adjustment screw first so that it touches. Now set the adjustment screw on the gear until you feel it hit the segment inside the gear, then turn it back about three turns and lock the adjustment screws by using the lock nut provided.



Always make sure the adjustment screws on the gear do not hit the worm segment. This prevents future failure and/or even injury.

2. Rotate the handwheel or use the actuator to move the valve to the fully open position.



If the valve is installed and you cannot see if the valve is fully open, you can count the number of rotations of the handwheel to make sure you reach 90 degrees.

Ex: (if your gear has a 100:1 ratio. You would rotate your handwheel 25 times to reach 90 degrees)

3. Set the adjustment screw by turning it clockwise until you feel it hit the segment inside the gear then turn it back about three turns. Lock the adjustment screw by using the lock nut provided.

SAFETY AND OPERATION



Do not use handwheels, cheater bars, or motors devices larger than recommended by the factory. This could cause damage to the gear operator or possibly the valve and will void the manufactures warranty

Gear operators are sized based on torque information provided by valve manufactures. Over time some applications will cause the valves to become stuck or more difficult to operate. If the operator becomes more difficult to operate make sure of the following:

- ❖ Does the gear have proper lubrication? Some valve applications like plug valves also need lubrication if this is the case also check that the valve has proper lubrication.
- ❖ Make sure the valve is clear of any obstructions.
- ❖ Check to see if the pressure across the valve has changed. This could have an adverse effect on the valve torque

In the event of a power supply failure, the pneumatic actuator will remain in its "fail position". First cut off the air supply to the actuator, then bleed the pneumatic actuator cylinders. Push the button on the handle assembly (step 1 below), located on the end of the shaft, and rotate the handle towards the "Engage" position following the arrow marked on the handle (step 2 below). In some cases the override gear teeth will not mesh correctly when rotating the handle upward. If this occurs do not force the handle, rotate the small handwheel so that the gears mesh properly and rotate the handle upward. It is important to remember not to force the handle if you cannot engage or disengage the gear. Moving the small handwheel on the gear will take the pressure off of the gear teeth making it easier to engage or disengage the gear. Reversing the procedure above will return the override to the disengaged position.



OPERATING INSTRUCTIONS

STEP 1:

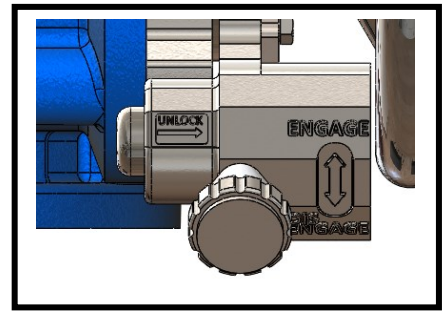
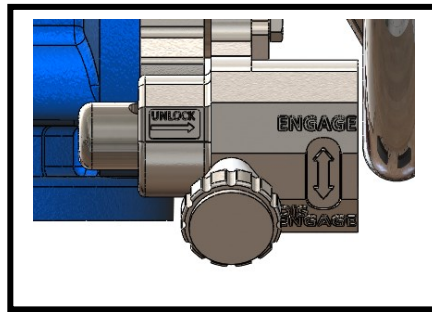
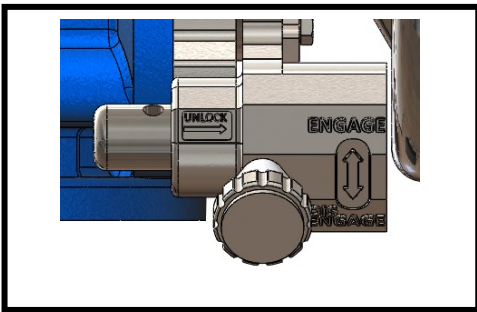

STEP 2:

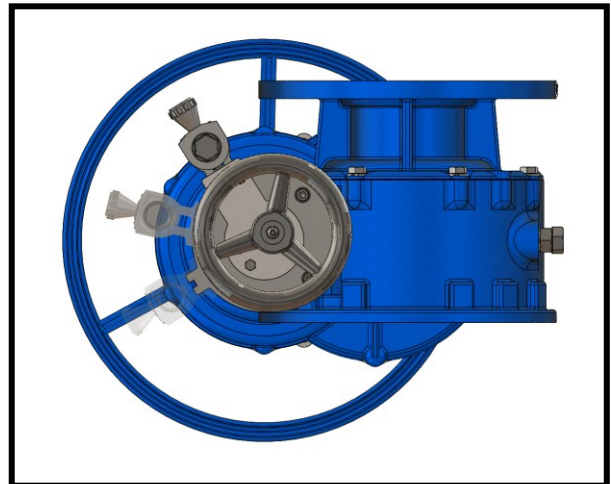
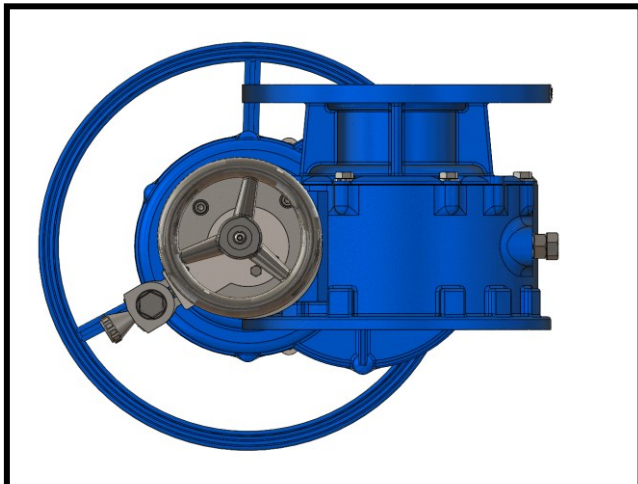



DECLUTCHABLE WORM GEAR Installation, Maintenance, & Operation Manual

STORAGE

Diamond Gear operators don't have a "shelf life" but ensure that the gears are ready when you are. DGC recommends they be stored in a clean, dry area protecting the input shafts and output bores from getting damaged.

MAINTENANCE

Moving mechanical parts are lubricated with special grease that ensures safe operation. Diamond Gear recommends that you inspect your gear annually for any wear that may occur, check gears and bearings for lubrication and add if necessary.



Please keep in mind that some gears may need to be inspected more often depending on application and environment.

In order to inspect the gear housing you will have to remove all the bolts that secure the mounting flange. Once these bolts are removed you can inspect the inside of the gear.

Diamond Gear operators are lubricated for life in most application instances. Depending on the environment and application some additional lubrication may be required.

Below you will find DGC standard gear requirements suitable for most applications:

- ❖ NLGI Grade 2
- ❖ Operating Temperature: -10 to 350 degrees F
- ❖ Timken Load (lbs) 65 or better

DECLUTCHABLE WORM GEAR Installation, Maintenance, & Operation Manual

WORM GEAR ASSEMBLY

